



## Sirene Eletrônica - TSCEX



### Características:

Sirene eletrônica para uso em áreas classificadas, fabricada em alumínio fundido. Possui os tipos de proteção "Ex d" - à prova de explosão, "Ex t" - à prova de ingresso de poeiras combustíveis e grau de proteção IP65. É fornecida com roscas BSP, NPT ou Métrica. Adicionalmente, pode ser fornecida com suporte.

Intensidade sonora: 105 dB a 1 metro.

Tensão de alimentação: 12Vcc, 24Vca/Vcc, 127 Vca/Vcc ou 240 Vca/Vcc.

Frequência: 60 Hz

### Aplicação:

Indicada para sinalização acústica industrial, onde haja risco de explosão como indústrias químicas, petroquímicas, farmacêuticas, processamento de alimentos, tintas e vernizes, armazéns de materiais inflamáveis e poeiras combustíveis.

Zona 1 e Zona 2, grupo de gás IIA, IIB e IIC

Zona 21 e Zona 22, grupo de poeira IIIA, IIIB e IIIC

### Acabamento:

Pode ser fornecida: **Natural** - Alumínio Fundido o corpo e a corneta. Ou nas cores que o cliente necessitar.

### Marcação:

Ex db IIC T5 Gb

Ex tb IIIC T100 °C Db

IP65

### Normas:

ABNT NBR IEC 60079-0

ABNT NBR IEC 60079-1

ABNT NBR IEC 60079-31

ABNT NBR IEC 60529



**ÚNICA NO BRASIL!**  
**FORNECIDA EM 100% ALUMÍNIO:**  
**CORPO E CORNETA.**



### NA COR QUE VOCÊ PRECISAR

Amarelo, Azul, Cinza, Natural, Preto, Vermelho, outras cores sob consulta.



Direito reservado a Telbra de mudar a qualquer momento as informações dos produtos, bem como acrescentar e/ou retirar produtos de linha.

Central de Vendas: **55 11 2946-4646** / [www.telbra.com.br](http://www.telbra.com.br) / [telbra@telbra.com.br](mailto:telbra@telbra.com.br)



# Sirene Eletrônica - TSCEX



a = Cor do Corpo	b = Cor da Corneta	c = Tensão	d = Furação Maior	e = Furação Menor
a = amarelo	a = amarelo	12Vcc, 24 Vca/Vcc, 127 Vca/Vcc 240 Vca/Vcc	b = 1" BSP n = 1"NPT m = M32	b = 3/4" BSP n = 3/4" NPT m = M25 ou M22
b = azul	b = azul			
c = cinza	c = cinza			
n = natural	n = natural			
p = preto	p = preto			
v = vermelho	v = vermelho			
* = consulte	* = consulte			

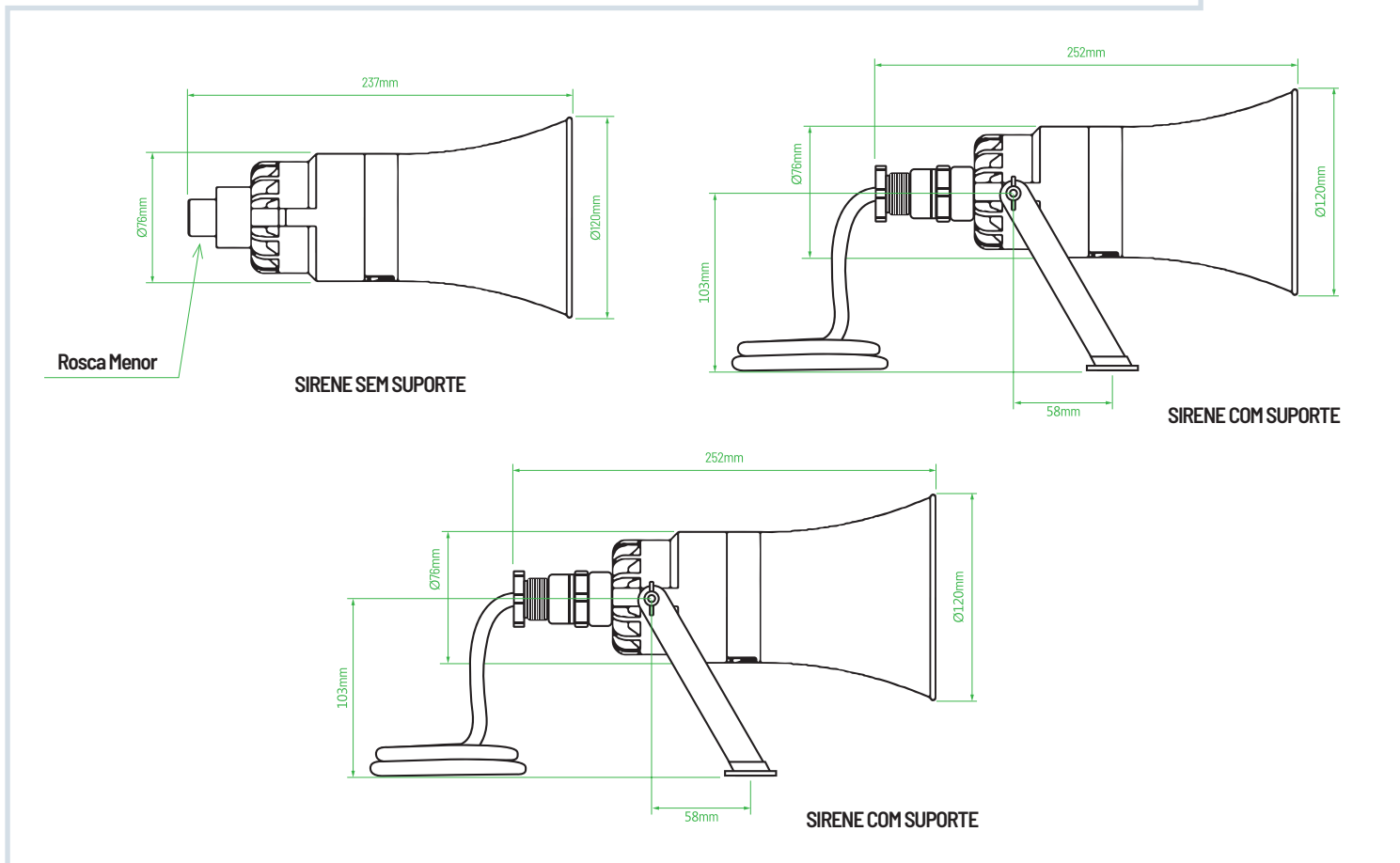

Direito reservado a Telbra de mudar a qualquer momento as informações dos produtos, bem como acrescentar e/ou retirar produtos de linha.